



Racer & Pro - Tube Bending Jig Instructions

This is a new product, we are still finalizing and improving the instructions. Make sure to read instructions completely, before using. We highly recommend watching the videos below before making any tubes as well. They are helpful for beginners and experts too. If you have any questions or feedback give us a call 9-5 PST or send a message.

Demonstration Videos - 911 Motorsports on YouTube - Tube Jig playlist or scan QR code →
There are multiple videos showing the different ways this can be used.



Left pic. below - The full **PRO** kit with all the goodies. The **RACER** kit does **NOT** have the Long Copes and Small Hinges... You get a pair of each hinge, with matching cope base. A pair of each cope and miter angle end. Along with Tube Masters and various extension tubes, with red lines to indicate center & max. extension. We also include two spare tube sleeves (used on extensions) these are the most likely fail point and easy to replace. Use a pick to remove, then install new one with a small bead of super glue.

Right pic. below - The end pieces are easy to swap for different cope angles or miters. Make sure to pay attention to the clocking ribs. Wiggle the cope ends when removing, they can get a little tight for a straight pull. All ends have notches to measure rotation, with included rotation checker (P shaped steel plate). Reference lines on ends for cope start, long cope transfer lines, miter short side, and 90° planes.

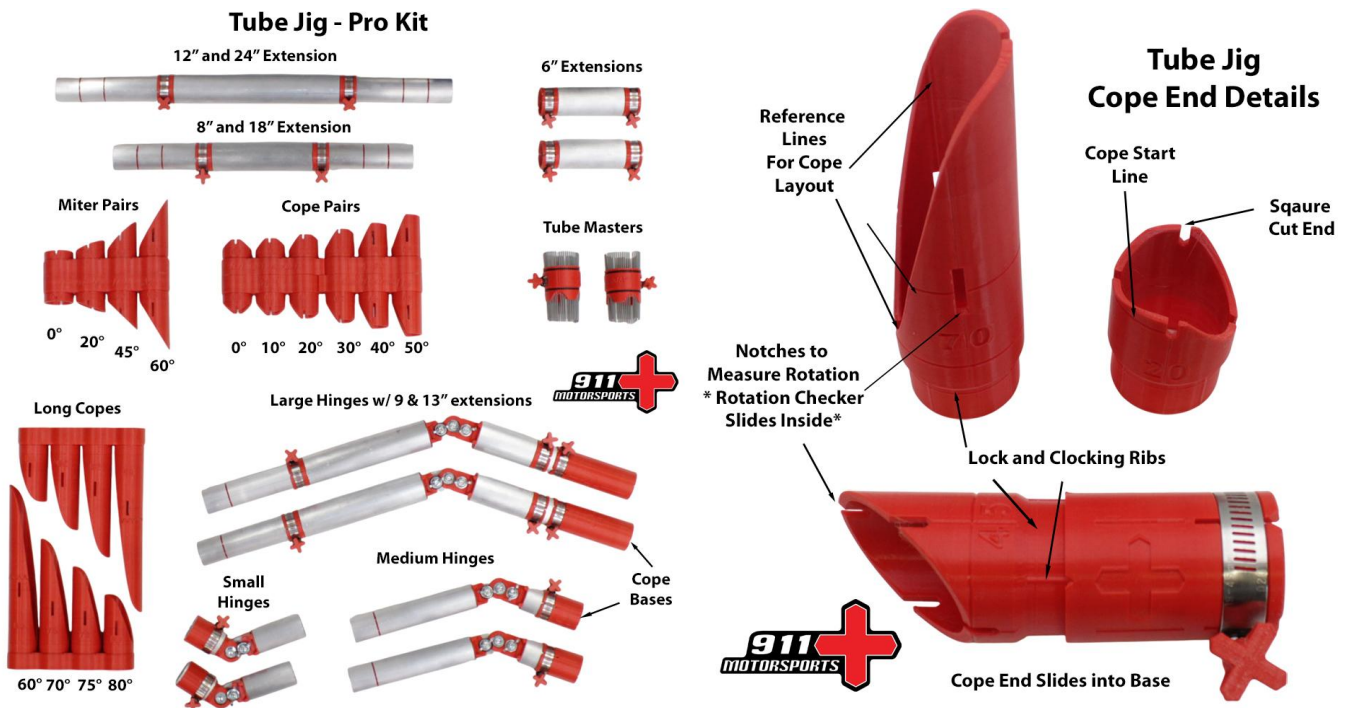

Tube Master

NOTE – Most Tube Masters have a lined hose clamp. The liner tail can affect needle tension if it goes inside hose clamp relief, keep hose clamp rotated so tail is exposed.

Using

- 1 -The included sleeve is for use with our smaller telescoping tubes.
- 2 -Start with the needles pushed back, align notches on tube and then push needles to match tube profile. You can start with some needles out, but keep the longest needles back and push them out, since they are most likely to flex away from tube.
- 3 -The clamp has two stages, light tension will hold the Tube Master while allowing the needles to still be adjusted. Then you can tighten it to lock the needles down and then work on the other side of your tube.
- 4 -When removing from test tube, loosen the clamp more than required to let it easily slide off and on the final tube to cope. Be careful not to touch the needles at this point.

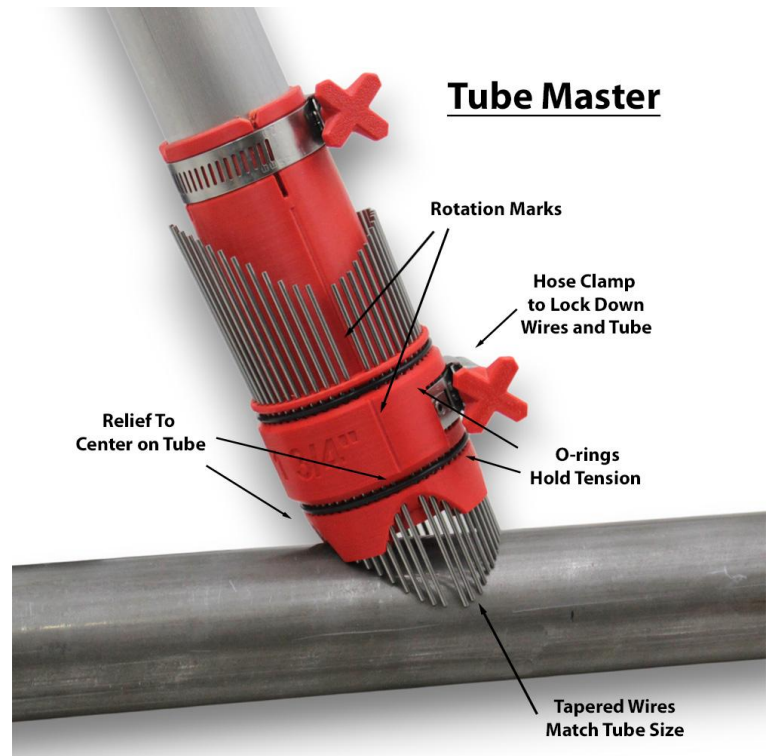

Tube Jig - Setup and adjustment

1. Start by getting rough measurements of the tube you want to bend.
2. Use the Cope-to-Hinge chart for the starting point. Then reference hinge-to-hinge charts to figure out multiple bend tubes. Work from the end to the middle when setting up the Tube Jig.
3. Assemble Jig, then adjust hinges and tubes to hold firm, but still be manipulated.
4. Final setup and fitment in the vehicle - Install and tweak the Tube Jig... use clamps, stands, or your buddy to hold it. These will also be used to hold the final tube.

Making a tube

1. Measure the final angle for your copes and write it down.
2. Then lay the jig on a table, if you set it up correctly the thumb screws(cross bolts) should be up in the air and not touching the table. This is important, so you can accurately measure bend rotation.
3. Transfer the numbers to your final tube - Mark centerline of bend first, then mark the tangent/start of bend and make sure to add the bend offset for your bender (formula below).
4. When doing two bends or more on a single tube, it is best to start from the center and work to each end.
5. Marking cope distance and rotation - Set the tube jig on top of your final tube if possible, center it between bends and transfer where the cope will start. If you can't do this then you will want to measure it using the centerline to tangent numbers, then transfer to the final tube.

Bend start explained - We made a YouTube video titled "Tube Bending – Start Point Offset layout" which shows all the steps below. This method makes it easy to make any bend without having to do all the math. Scan the QR code for a direct link.



Finding tangent of bend in the centerline - This is NOT where the tube crushes, but usually pretty close. Set an angle finder to the desired degree of bend and hold it against the radius die on your bender. Make a mark where the angle finder contacts the die, this is the tangent point. Measure from your tangent mark to the center of angle finder (where legs intersect, not the pivot), this is the distance from center of bend to tangent/actual start of bend. This works because every size and radius of any die is exactly half the tube, the center line.

Bend location offset - This is the distance between where the bend truly starts in the die (tangent) and the position on the die or bender where you line up the bend start point.

Finding your offset - Cut a piece of tube that will allow you to make a 90 degree bend. Place a mark a couple of inches down the tube (we are going to use 3" in our example, on 1 3/4" tube with a 6" CLR die). Lineup the tube mark to the point on the die or bender you would like to use as your start mark, e.g. edge of die, strap, screw... Bend the tube creating a 90 degree bend. When completed hold a large square on the outside of the tube, measure the leg length (marked tube) from the end to the square. In our example below the leg measured 10.5".

Formula: Bend Location Offset = CLR + Mark Location + (1/2 of the OD) - leg length

Example: Bend Location Offset = 6 + 3.0 + .875 - 10.5 = -.625 (5/8")

Now we know the tangent or actual start of bend is 5/8" from our mark. That is the bend offset to add for this bender/die setup when bending.

Charts - These are meant to be used for quick reference when setting up the Tube Jig. For most tubes start with the Cope to Hinge chart, this dictates which hinge will be used at the end. Then reference the Hinge to Hinge charts below to figure out which hinge is required for the next bend.

Cope to Hinge Setup Chart

Small Hinge

Short Side
2 3/4" to 5"

Long Side
4 1/2" to 7"

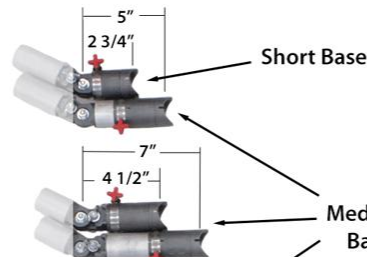

Med. Hinge

Short Side
5" to 10"

Long Side
9" to 14"

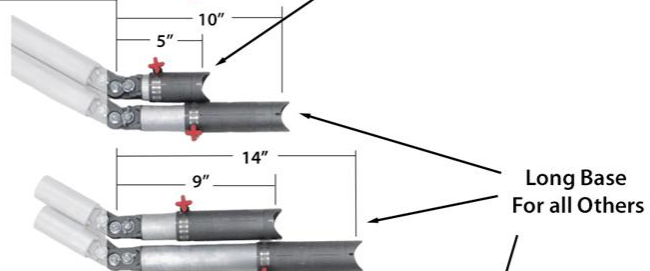

Large Hinge

Short Side
11 1/2" to 19"

Long Side
15 1/2" to 26 1/2"

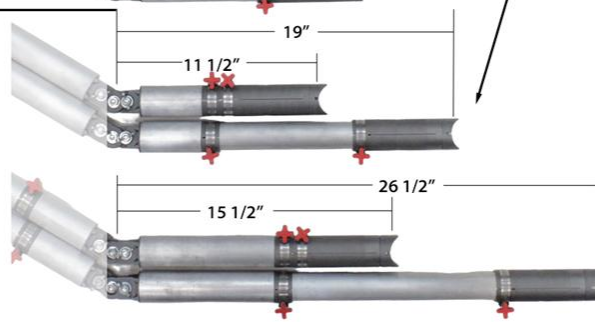

Medium Hinges

-Short Side to Short Side
10" to 13 1/2"

-Short to Long
14" to 19 1/2"

-Long to Long
18" to 23 1/2"

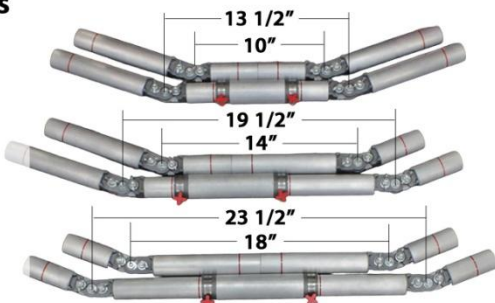

Large Hinge

Short Side

- Medium Hinge - Short Side

- Medium Hinge - Long Side

Large Hinge

Long Side

- Medium Hinge - Long Side

Large Hinge w/ 6" Ext.

- Med. Hinge Short side - w/ Short Tube

- Med. Hinge Long side - w/ Long Tube

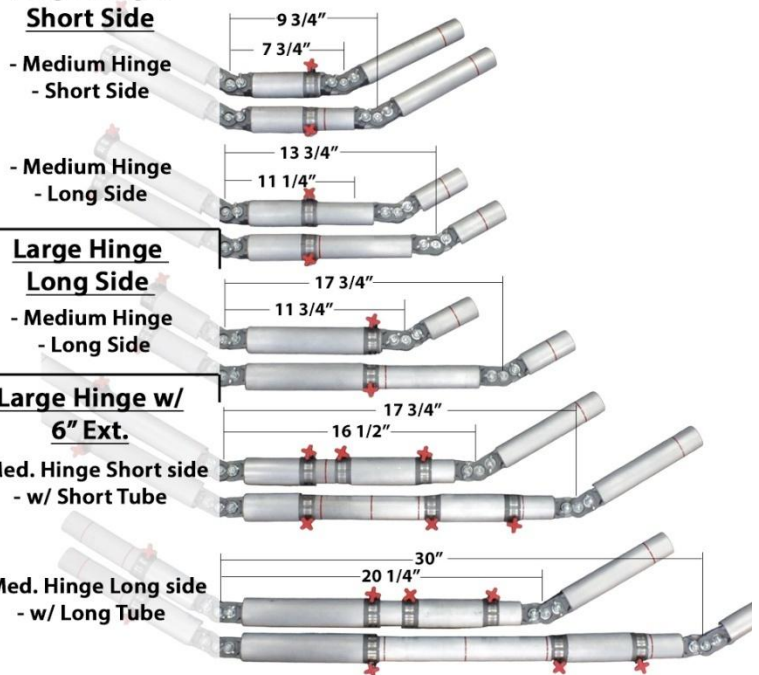

Large Hinges

-Short Side to Short Side
13 1/2" to 18 1/2"

-Long to Short
17 1/2" to 26 1/2"

-Long to Long
20" to 30 1/2"

